

# **SUNSTREAM**

## **BOAT LIFTS**

# **SL4010AR/SL6012AR™**

ASSEMBLY, INSTALLATION, AND USE MANUAL

---

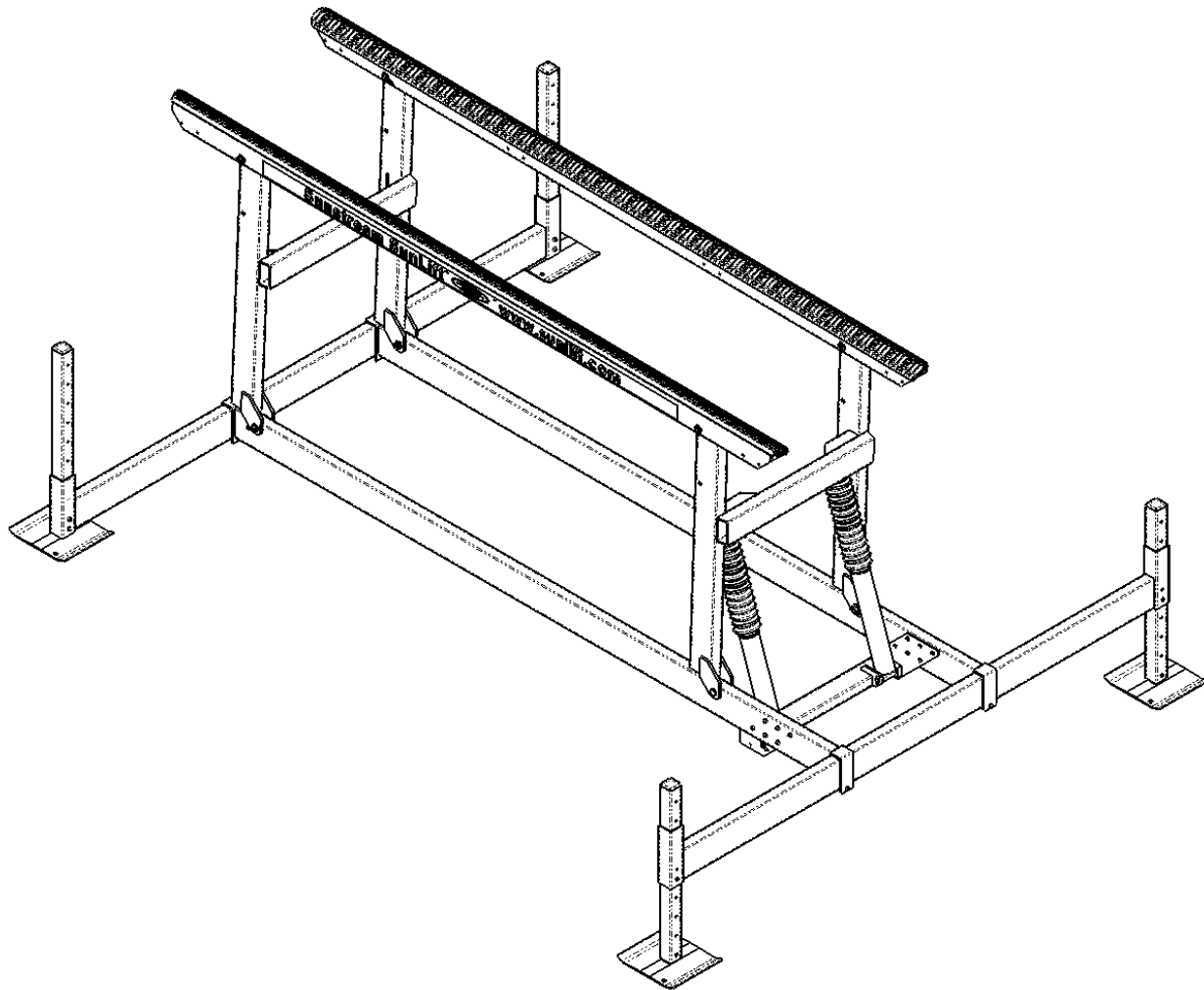

**READ CAREFULLY.  
KEEP THESE INSTRUCTIONS.**

---



## TABLE OF CONTENTS

3.....	SUNLIFT COMPONENTS
4 - 11.....	ASSEMBLY
12 - 13.....	INSTALLATION
14.....	IMPORTANT SAFETY INSTRUCTIONS
15.....	USE AND MAINTENANCE
16.....	BATTERY TIPS
16.....	REMOTE CONTROL PROGRAMMING
17.....	TROUBLESHOOTING TIPS
18.....	WARRANTY

### DISCLAIMER OF LIABILITY

These assembly and installation instructions have been provided by Sunstream Corporation at the request of the potential installer and/or assembler. If you are not an authorized Sunstream Dealer and are not a reasonably skilled mechanic, please contact Sunstream so that we can refer you to a local dealer who can skillfully and safely perform the assembly and installation of your Sunstream boatlift. It is the potential installer and/or assembler's responsibility to determine whether he or she has the necessary skills, knowledge, and tools to properly and safely assemble and/or install the Sunstream Lift described herein. Improper assembly and/or installation may cause the Lift to function improperly or not to function. Improper assembly and/or installation may additionally cause a risk to personal safety or property. If the assembler and/or installer is confused or has questions or concerns about a particular assembly or installation, he or she should contact Sunstream by telephone at (888)-786-5438 before proceeding further. The information contained in these instructions does not constitute a warranty or guarantee of any kind.

**An assembler's and/or installer's failure to correctly follow these assembly and installation instructions constitutes a waiver of the assembler and/or installer's rights against Sunstream regarding any subsequent damages to property or personal injury caused by the assembler's and/or installer's improper assembly and/or installation**

# SUNLIFT COMPONENTS

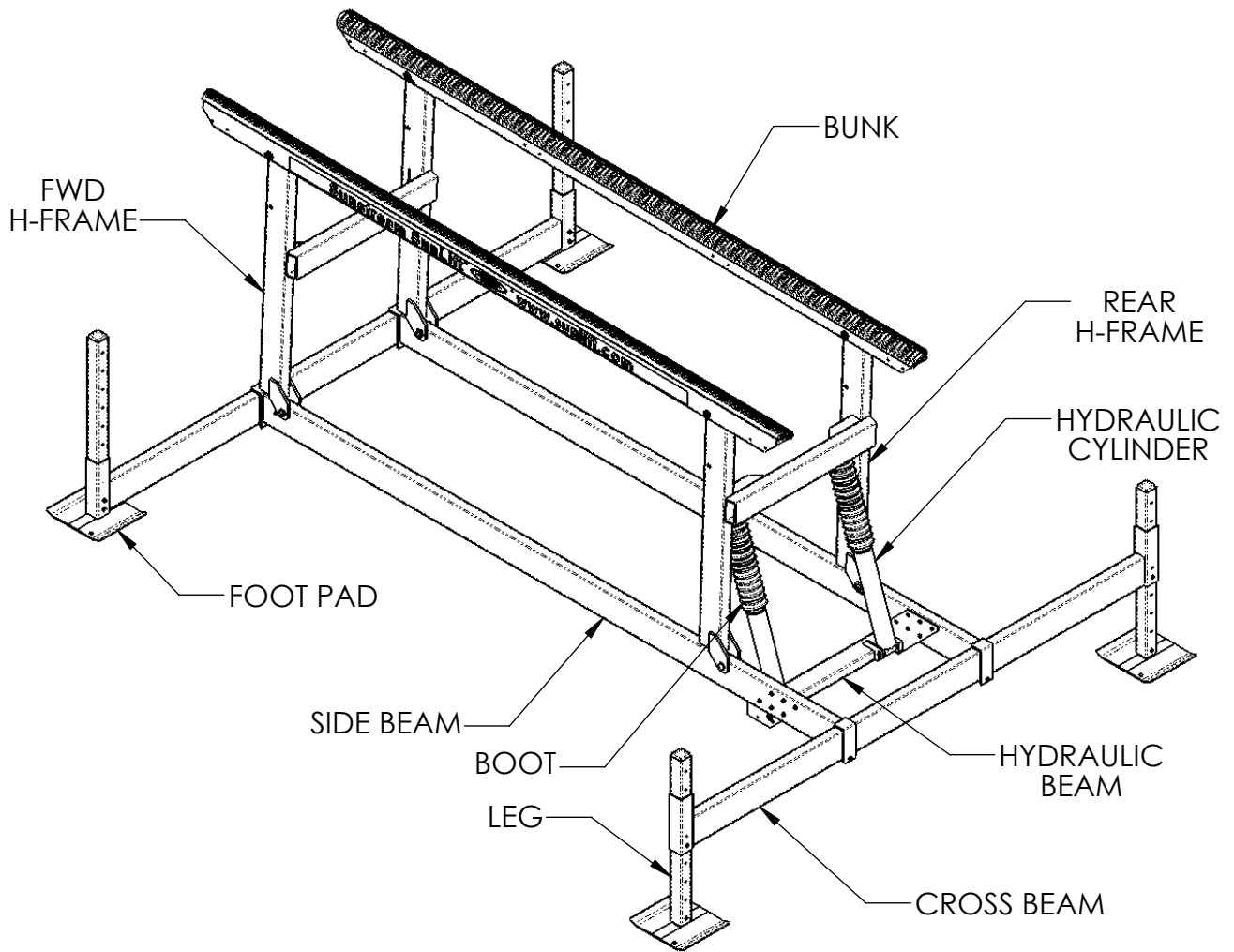

# ASSEMBLY



***If you have any questions during the assembly process, please call your local dealer or Sunstream at (888) SUN-LIFT.***

Before beginning assembly, find a nice flat area with room to work to set up your lift. Read ahead to the Installation Procedure to determine the best location to start. Assembly will require the following tools:

- Wrenches, adjustable and/or socket (9/16")
- Marine Grease (Stainless Pivot Pins)
- Needle Nose Pliers (cotter pins)
- Hammer
- Measuring Tape (locating side beams on cross beams)
- Antiseize (fastener threads)

**DO NOT SUBSTITUTE MARINE GREASE FOR ANTISEIZE  
DISCARD ALL PACKAGING BOLTS. DO NOT USE TO ASSEMBLE LIFT.**

**1**

**12X**

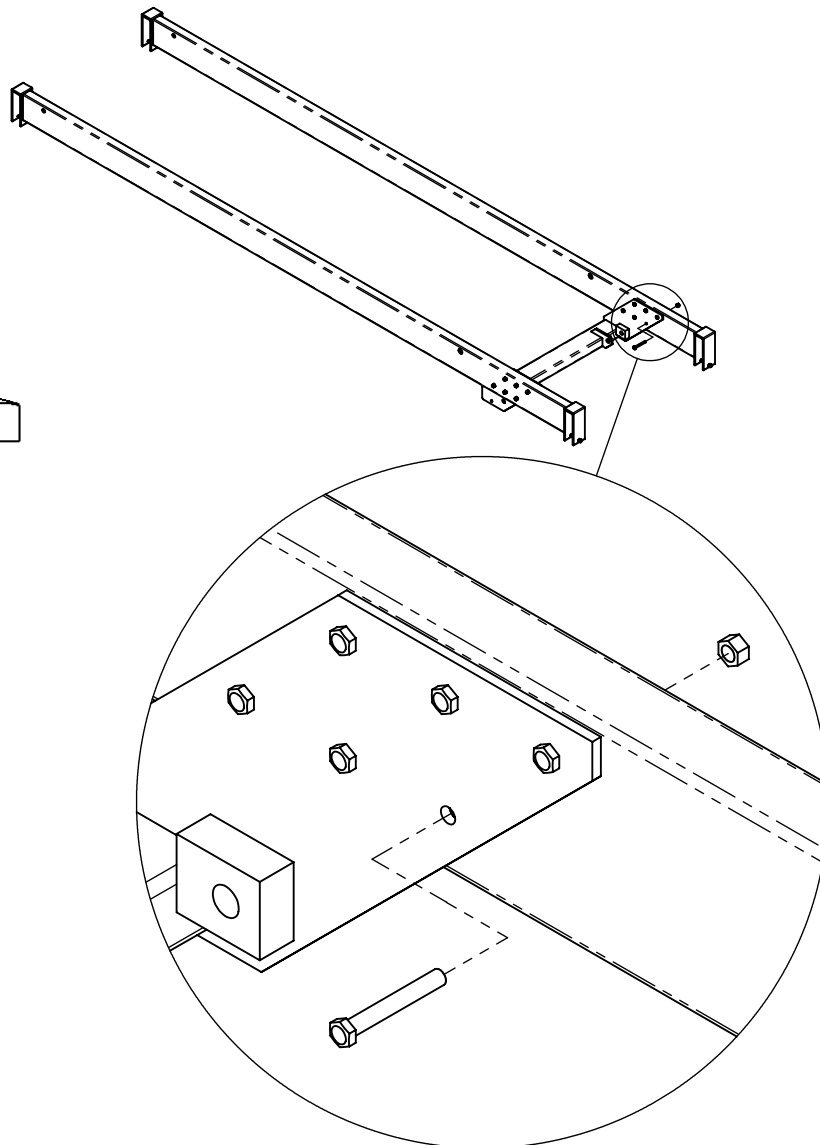
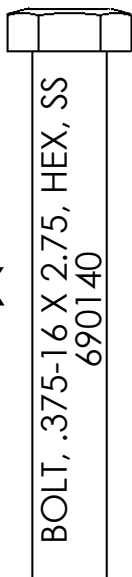

**12X**

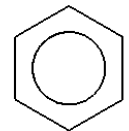

NUT, .375-16, SS  
12-060000-21

# 2

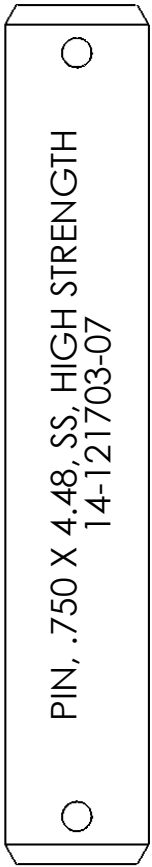

**2X**

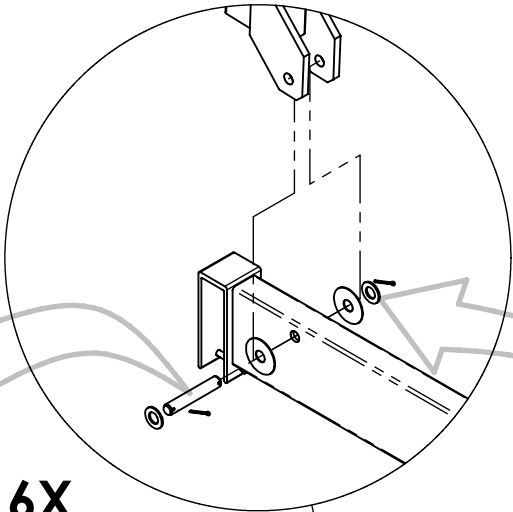

**6X**

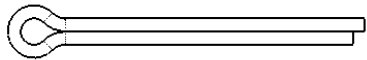

PIN, COTTER, .125 X 1.50, SS  
14-020700-33

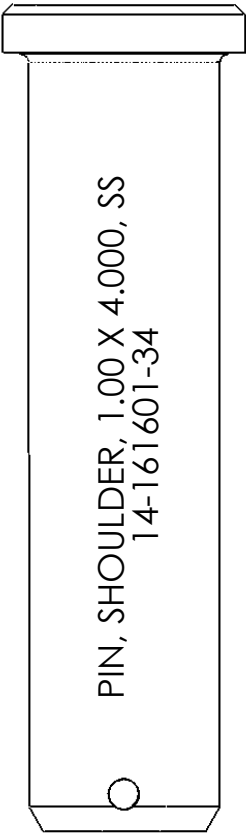
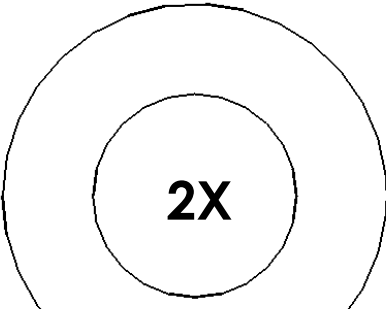
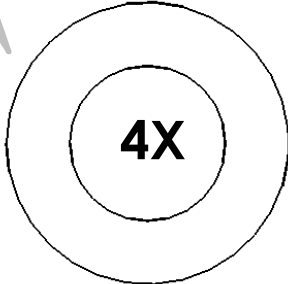
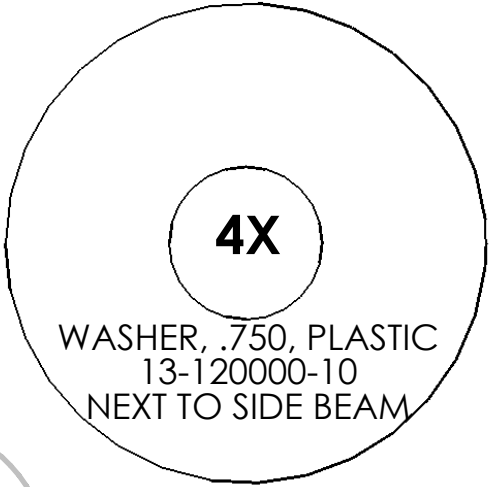

**2X**

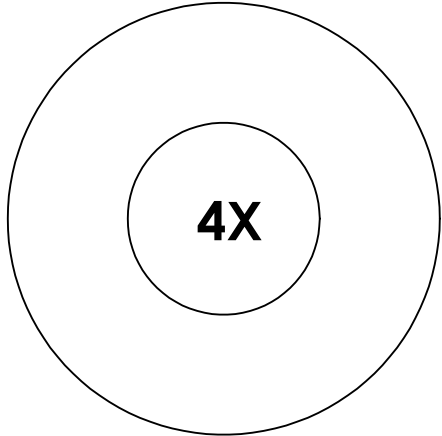
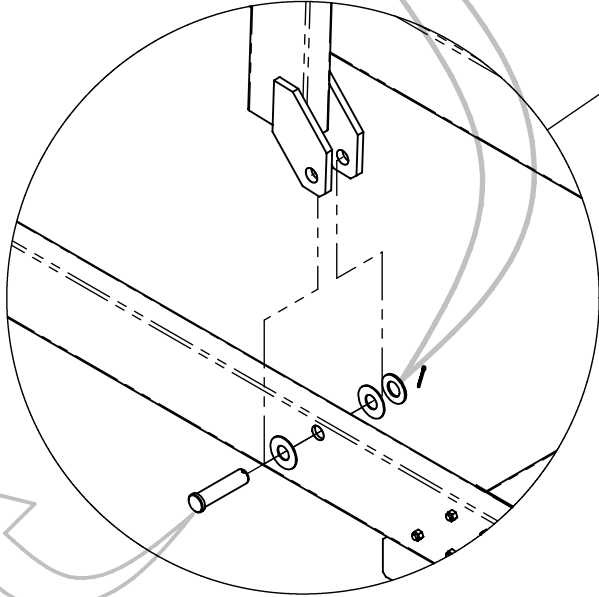

**SUNSTREAM  
BOAT LIFTS**

**3**

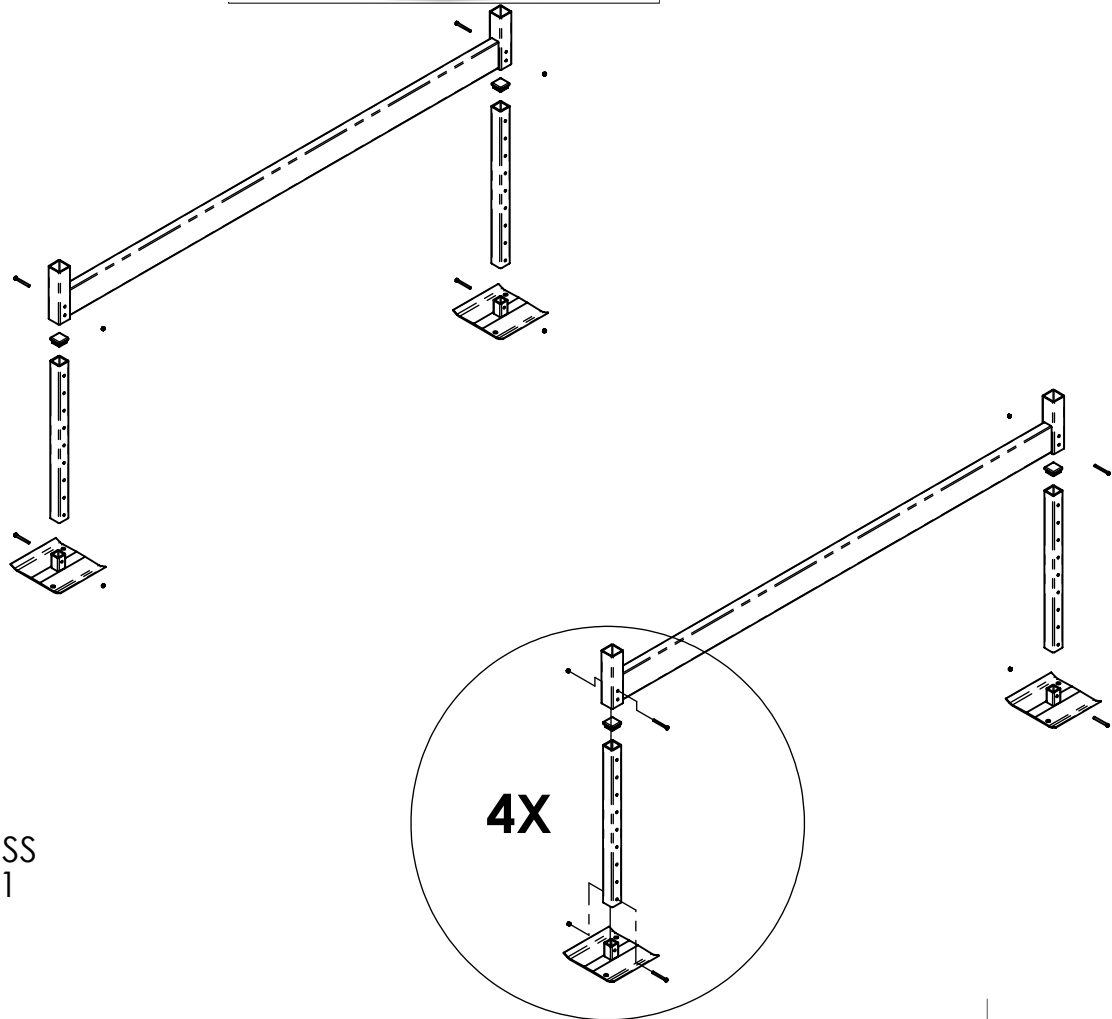

**8X**

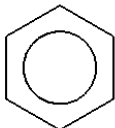

NUT, .375-16, SS  
12-060000-21

**8X**



BOLT, .375-16 X 3.50, HEX, SS  
11-061400-17

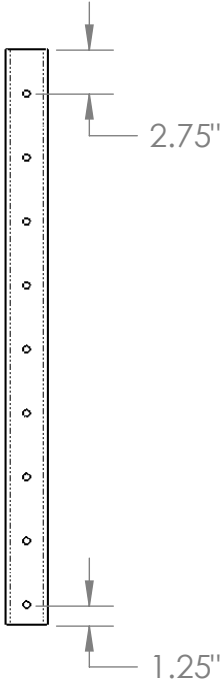
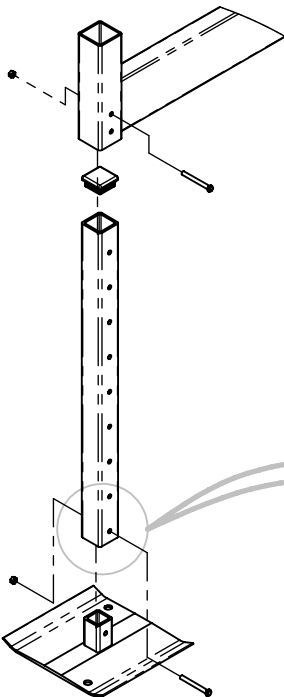

**4**

**SL6012AR**

**SL4010AR**

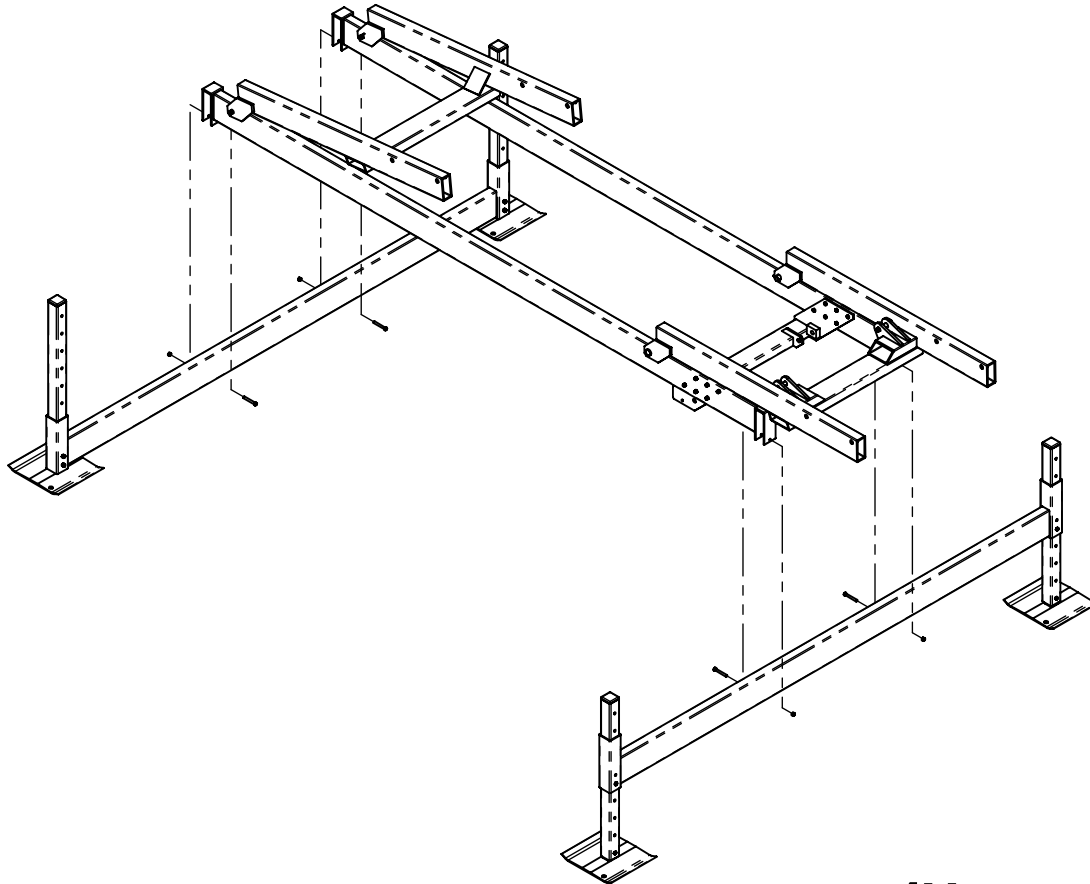
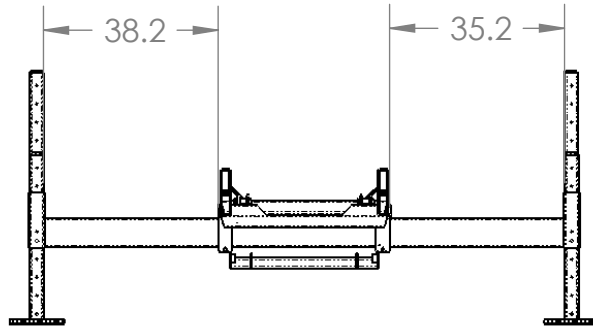

**4X**

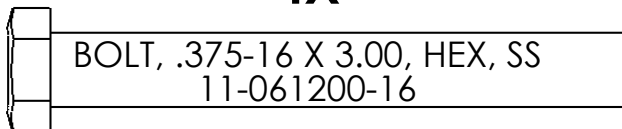

**4X**

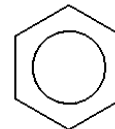

NUT, .375-16, SS  
12-060000-21

**5**

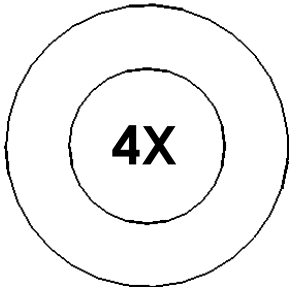
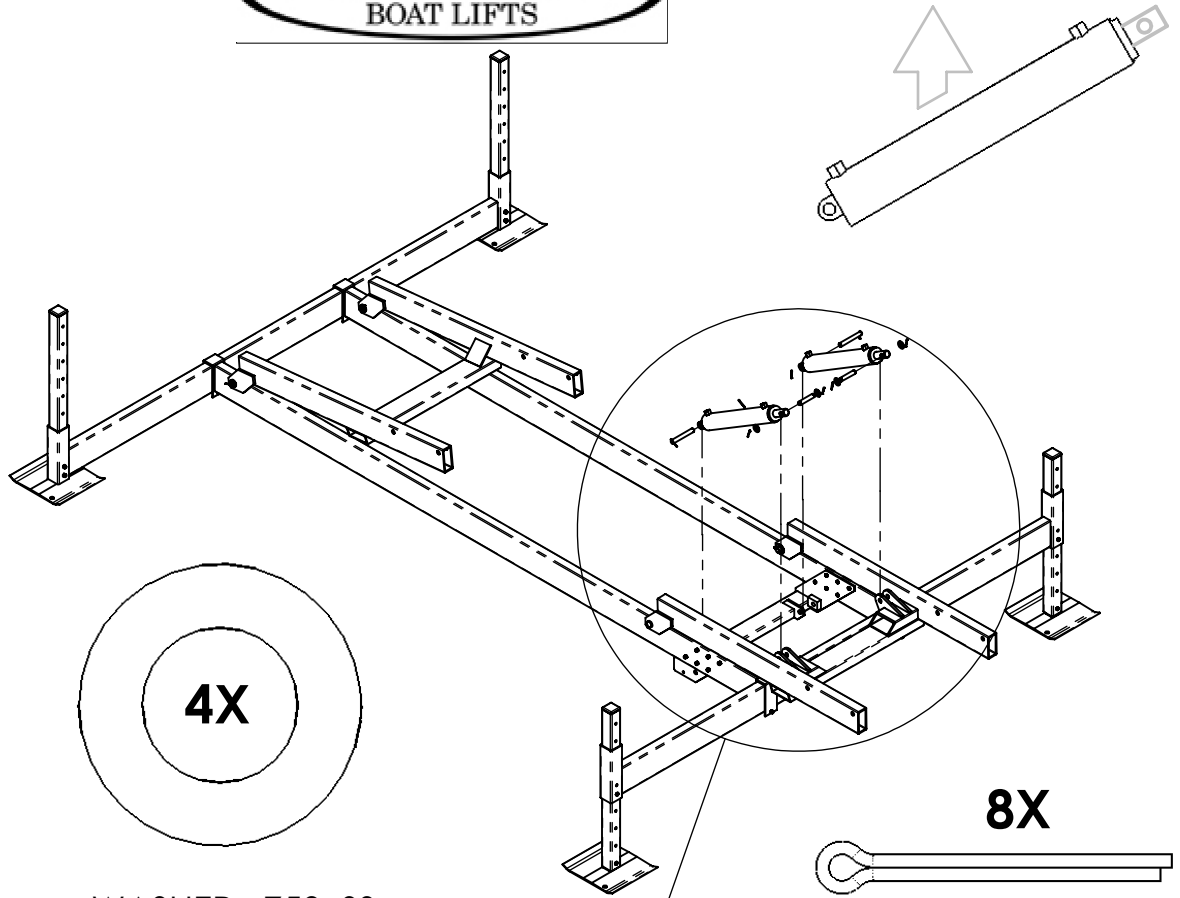

**4X**  
WASHER, .750, SS  
13-120000-59

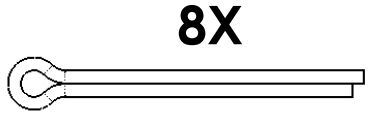

**8X**  
PIN, COTTER, .125 X 1.50, SS  
14-020700-33



**2X**  
PIN, .750 X 5.625, SS, HIGH STRENGTH  
14-122102-04

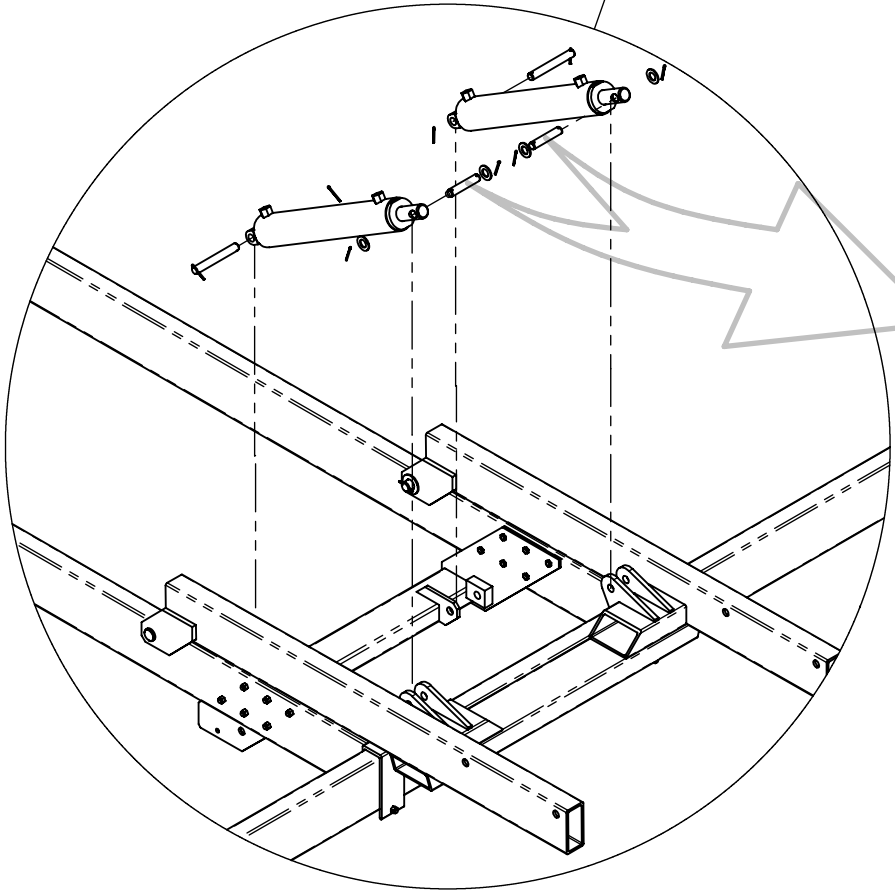

**2X**  
PIN, .750 X 3.75, SS, HIGH STRENGTH  
14-121500-08

**6**

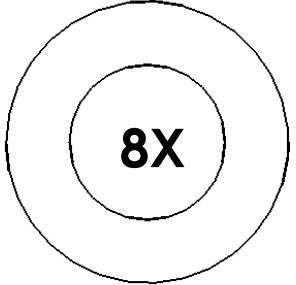
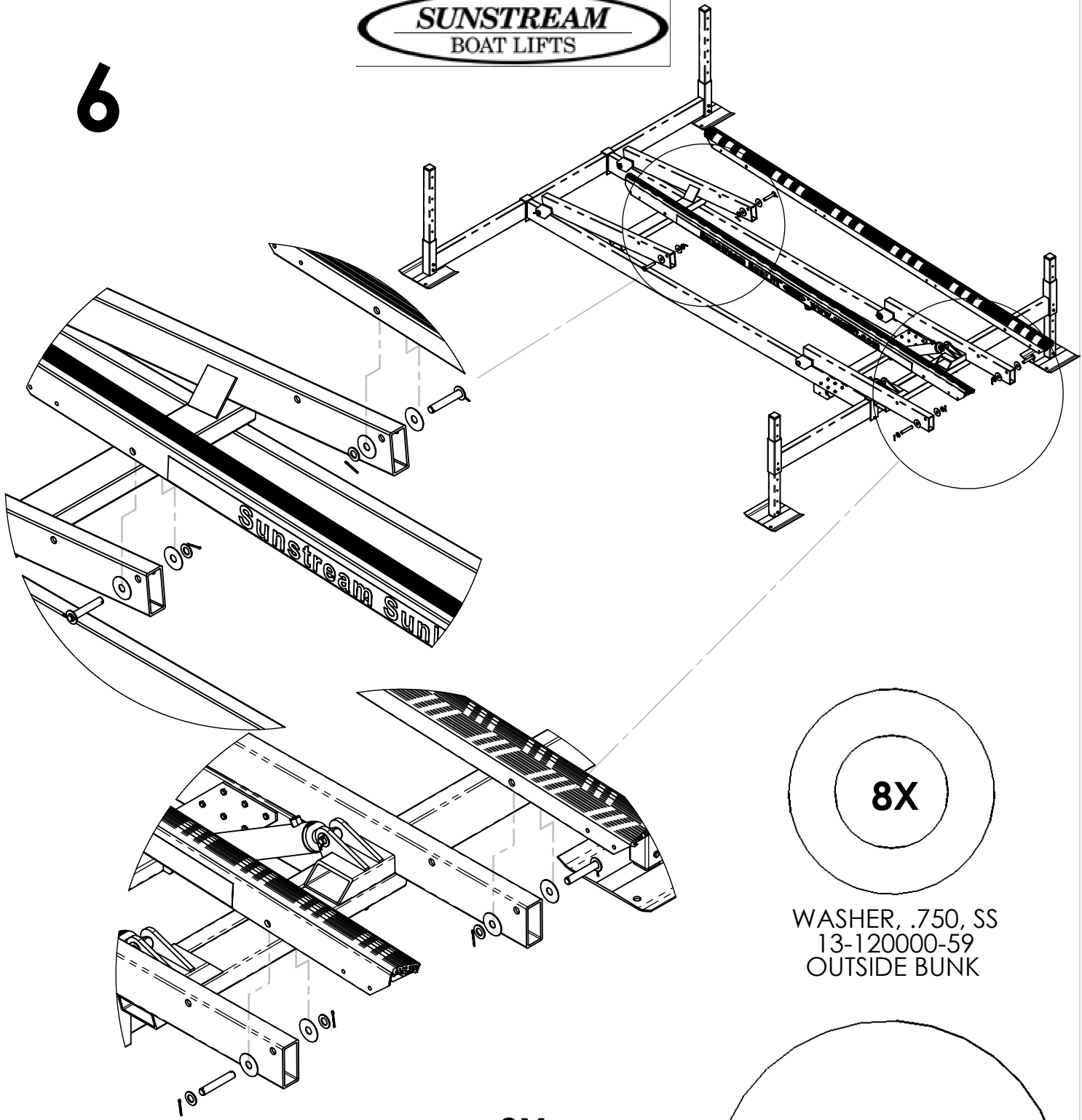

WASHER, .750, SS  
13-120000-59  
OUTSIDE BUNK

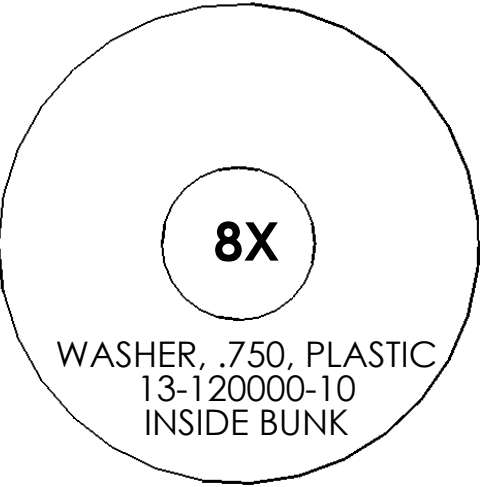

WASHER, .750, PLASTIC  
13-120000-10  
INSIDE BUNK

**8X**

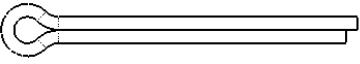

PIN, COTTER, .125 X 1.50, SS  
14-020700-33

**4X**

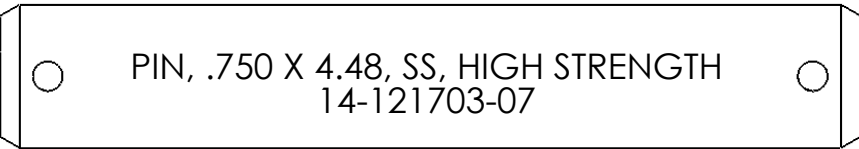

PIN, .750 X 4.48, SS, HIGH STRENGTH  
14-121703-07

# 7



## TIGHTEN ALL BOLTS & CHECK COTTER PINS

At this time, verify all cotter pins are properly bent to prevent removal, and check that all bolts (except leg bolts) are tight. Use CAUTION not to over tighten fasteners.

# 8

## ZINCS - INSTRUCTIONS & INSTALLATION

To ward off corrosion, it is essential that "sacrificial" zinc(s) are installed and maintained on your lift. Zinc is used as it has a higher voltage in water so the current will be more inclined to flow from it. The zinc becomes the corroding anode, while the lift serves as the cathode and is protected from corrosion.

**It is imperative that you replace the zinc on your lift regularly.** Because many external factors affect the rate at which a zinc deteriorates, Sunstream recommends that you check its condition frequently, and change the zinc every six months or more often if needed. Zincs on lifts in coastal areas near the ocean deteriorate more rapidly and need to be changed more frequently. **Effects of galvanic corrosion are not covered by your Sunstream warranty. Not maintaining zincs on the lift constitutes abuse and voids the Sunstream warranty.**

**Protect your investment with the proper steps.** To complete the electrical circuit, the zincs must be connected to the lift as shown below. Sunstream would be pleased to provide zinc replacement services; simply call to schedule. If replacing your own, Sunstream recommends using high-quality zincs that are available through the Sunstream service department.

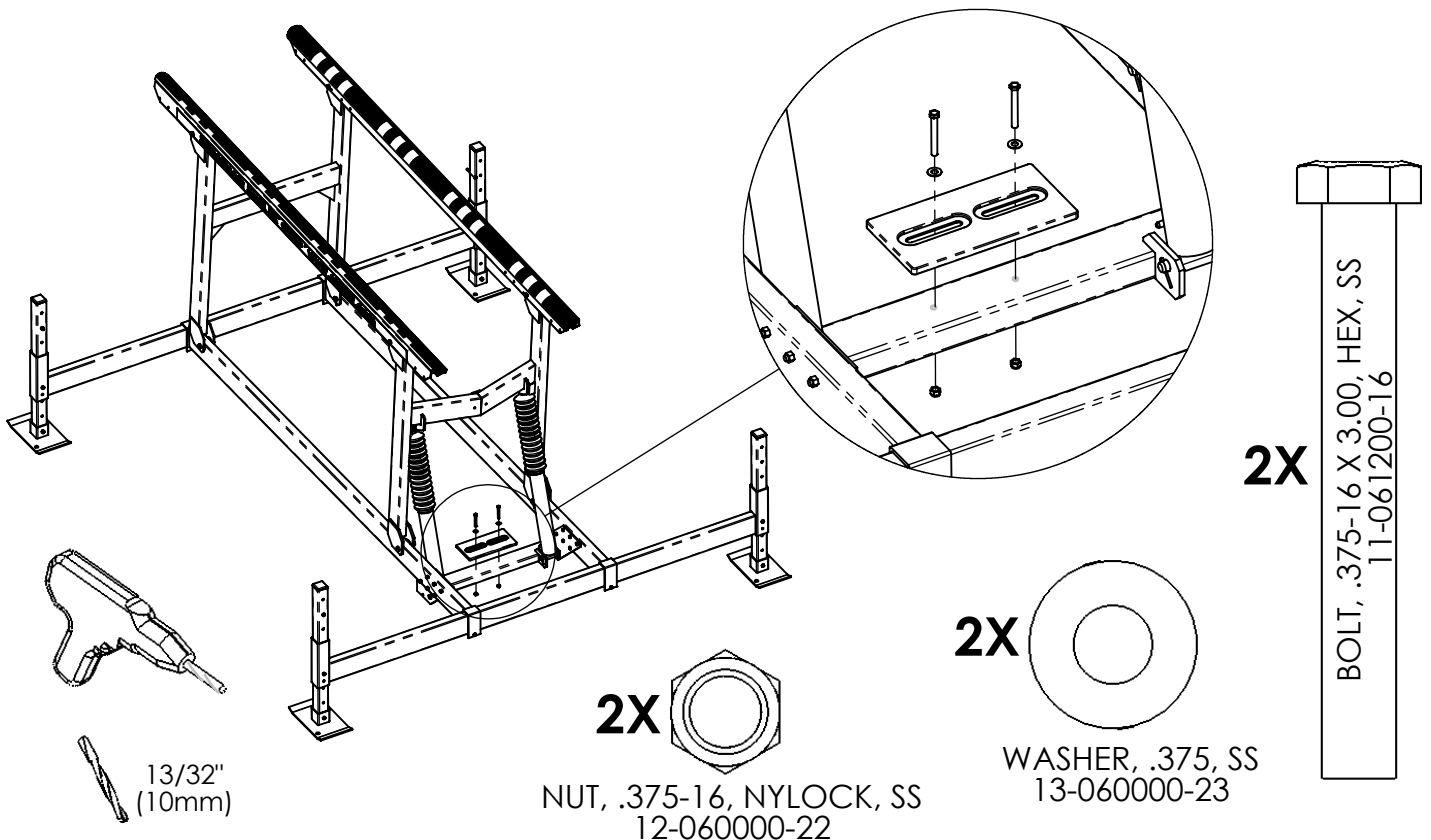

# 9

## PREPARE HYDRAULIC SYSTEM

Be sure to route the hydraulic hoses *under* the *Side Beam* to prevent pinching by the lift when operating. Insert the hoses through the holes in the side of the Power Pack box, and connect to the pump using the quick-connect fittings.

**Important:** If the quick-connect fittings are difficult to attach, then you should relieve some of the pressure in the system by pushing in on the tip of the male hose connector (try pressing the tip against a clean hard surface). NOTE: Use eye protection! Use caution not to damage fitting. This will release a small amount of fluid, which is O.K. Once the pressure has been released you should be able to connect both hoses. Remember that the hydraulic fluid in your SunLift is water-soluble and safe, and cleans up easily.

**Lighting package only:** If you installed the optional light bar on your lift, you should also route the light bar wire along with the hydraulic hoses to your Power Pack. Insert the wire through one of the holes in the side of the box, and plug in to the connectors marked 'Lights'. Use the plastic wire ties provided to attach the wire to the hydraulic hoses.

Attach the red battery lead to the positive battery terminal, and the black lead to the negative terminal. **Tighten** each wing nut with a pair of pliers, as even a slightly loose connection will cause the battery terminals to heat up. Keep battery terminals clean. Applying a corrosion protective coating will help keep the terminals clean.

**Caution:** Use care when working inside the powerpack box and around the battery, just as you would around your car or boat battery. A battery can explode and cause harm.

Finally, verify that the system is switched 'on'. The on/off switch is located inside the Power Pack on the side of the electrical control box.

# 10

## TESTING LIFT ON DRY LAND

You are now ready to test your lift before you put it in the water! It is important that this be done for the first time without anything loaded on the lift.

Use the up/down switch inside the Power Pack to cycle the lift up and down. As you are doing this, pay close attention to the hydraulic hoses to see that they are not binding or being pinched by any part of the lift. Also, the lift should move up and down smoothly, without any undue stress or squeaking. If there is an excessive amount of squeaking or binding, check to see that all pivot pins are properly lubricated. After cycling the lift a couple of times, make one last inspection of the cotter pins and bolts to see that they are secure and tight. If applicable, also test the optional remote control and underwater lighting system.

**Important:** Inspect all hoses carefully for leaks. Tighten leaky fittings if necessary. Do not over-tighten fittings.

**YOU ARE NOW READY TO INSTALL YOUR LIFT**



# **INSTALLATION**

## **! WARNING**

The Maximum Capacity for the Lift should be listed on the lift itself - if it is not, call Sunstream immediately to determine your lift's capacity. Operating the Lift with a greater amount of total weight may cause the Lift and boat to become unstable and/or capsize, possibly causing property damage and/or severe injury or death to individuals situated nearby.

## **! WARNING**

Installation or use of the Lift in overly rigorous conditions may cause the Lift to become unstable and/or capsize, possibly causing property damage and/or severe injury or death to individuals situated nearby.

# **LAUNCH THE LIFT**

Before launching, you must consider at what depth the lift should sit in order to best utilize the lifting height, especially if your water level fluctuates during the year. Typically, the front and rear crossbeams of your Sun Lift should be between 24" to 48" below the surface of the water for 48" range models of the SL2510 through SL8012. The extended range (ER) models will require 6" to 12" more depth depending on the draft of the boat. Attempt to maximize the lifting height, since over time wave action can damage the lift if the waves are contacting the boat.

### ***If your water level fluctuates during the year:***

Position the top of the *Cross Beam* 24" below the surface at the lowest water level. A standard Sun Lift with 48" of lifting height will allow for about 24" of water fluctuation. The extended range Sun Lift with 60" of lifting height will allow for about 36" of water fluctuation.

### ***If your water level does not fluctuate:***

You can position the top of the cross beams anywhere between the 24" and 48" depth measurement, depending on how high you want your boat out of the water.

In preparation for launching the lift into the water, disconnect the hydraulic hoses (and optional light bar wire if applicable) from the Power Pack. Connect the hydraulic hoses to each other to protect the connectors and keep them clean during installation.

## **A. To launch your lift:**

- 1. 'Float' the lift into position using flotation.** In some cases, it may be necessary to employ a certified diver for this type of installation to make final underwater adjustments, and tighten all hardware. **This is especially true if your leg lengths are 8 feet or longer, since deep water braces would be required.** Check with your local dock builder or boatlift installer if you feel you need help. To perform this type of installation, you will need suitable flotation for the lift, which will hold it at the surface of the water while you position it and make final adjustments. We recommend a couple of 250 lb. float bags. The flotation should be strapped *tightly* to the fore and aft 'H' frames of your lift.

If you have not already done so, insert the legs into the leg sleeves at all four corners, and attach the feet. Temporarily bolt the legs to their shallowest setting. The lift should be in the full down position prior to launching, and the hydraulic hoses disconnected from the Powerpack. Put the lift in the water, and float it to the approximate area where you would like it to sit. Note that if your legs are exceptionally long, it may be easier to insert them after the lift is placed in the water, as the entire structure will then be less cumbersome. Now remove the bolt holding each leg into position, and allow the leg to drop to the bottom. Bolt it into position using the nearest hole. Re-connect the hydraulic hoses to the Powerpack so you can use the power of the lift combined with the flotation of the barrels to level the lift (see next step).

After the braces are in place, and all adjustments are complete, remove flotation.



## **LEVELING AND FINAL POSITIONING**

### **A. Leveling the Sun Lift:**

Once you have adjusted the lift in its final position, you must now ensure that it is level. To do this, use a suitable measuring device and measure the distance from the top of the *Cross Beam* to the water surface. The distance at each of the four corners of the lift should be within 2 inches of each other. If they are not, you will have to adjust the leg(s) up or down accordingly. Note the two holes in the leg sleeve allow you to adjust the leg in 2" increments.

### **B. (optional) Attach deep water braces (for leg lengths 8 feet and up):**

If you have legs over 7' long, you will be required to attach deep water braces to stabilize and strengthen the structure underneath the water. Refer to the Deep Water Brace Kit instructions for details. Note that once these braces are attached, the legs are not easily adjusted, so make sure you are finished leveling before attaching braces.

**C.** Double check at this time that **all** bolts and nuts are tightened. Also, if your area experiences high wind and waves, or if the lake bed slopes to some degree where your lift sits, you may consider driving four 2 ft. pieces of rebar (not provided) through the holes provided in the feet for added anchoring. (Determine whether environmental or other laws prohibit or require a permit before penetrating the substrate.)

For steep slope installations, pin down foot holes with 4 ft, 1/2" dia. rebar (not included).

## **LIFT YOUR BOAT**

You are now ready to lift your boat for the first time.

### **! WARNING**

Note that the weight of the boat on the lift for the first time may cause it to settle. Therefore, great care and precaution should be taken when lifting for the first few times until you are certain the lift is stabilized. Make sure everyone in the immediate area is aware during this process, and is not in close proximity to the lift (especially not in the water near the lift!)

Position the boat by **hand** over the bunks with the transom about even or 12 - 18" behind the back of the bunk. Carefully bring the lift up until the bunks 'capture' the boat. If so, continue bringing the boat out of the water until it is about 1 foot above the surface. Stop the lift again and check the stability of the lift, particularly to see that it is remaining fairly level and will not topple over. Finally, continue lifting the boat while paying close attention to the positioning of the lift until it is in the full upright and over-center position.

Remove the boat from the lift. Check to see that the lift is still level. If not, the leg(s) will need to be adjusted again accordingly. Then, two weeks after the installation, check to see that the lift is level as it may have settled over time. Adjust as needed. Inspect the lift level periodically as needed.



# **IMPORTANT SAFETY INSTRUCTIONS**

*If you have any questions, please call your dealer, or Sunstream at (888)786-5438*

## **Save These Instructions**

Your safety and the safety of others is very important. Proper use of the information in this manual will help avoid potential hazards that could cause damage to property and/or personal injury. It is not possible, however, to identify and warn users of all hazards associated with the assembly, installation, operation, and maintenance of the FloatLift. You must use your own good judgment.

## **SAFETY WARNINGS**

**\* Failure to comply with the following rules may result in severe injury and/or death and damage to property. Misuse of your lift may cause the lift and boat to become unstable.**

1. Your Sun Lift is a piece of heavy equipment and the act of raising your boat should be treated with respect and good judgment. Children should not operate lift without adult supervision.
2. No one should operate the lift without fully understanding the proper operating procedures.
3. **NEVER** exceed the maximum capacity of the lift. Overloading may result in mechanical failure and personal injury. Positioning the boat too far forward or aft may overload the lift.
4. Your lift is not designed to be an elevator for people. Therefore, do not use the lift for moving or supporting humans. Load and Unload passengers only when boat is floating.
5. Restrict children and adults from playing on or near the Sun Lift.
6. It is safest to leave the boat in the over-center position.
7. Be sure the Sun Lift remains level at all four corners. Out of level installations may cause lift failure and personal injury. All four corners must be within 2" of each other.
8. **NEVER** go under your boat when the lift is in the raised position. Also, your lift is not design to be a maintenance platform. Service and maintenance work on your boat should be performed at a proper marine facility, and not while on your Sun Lift.
9. Do not use your Powerpack for storage purposes. Articles or tools in the box could cause damage to the pump or electrical system.
10. Do not disconnect quick-connect hydraulics with a boat loaded on the lift and not in the over-center position. It is difficult to re-attach the hoses if the hoses have pressure.
11. If a Sun Lift is located near an area where swimmers are prone to diving into the water (such as off of a boathouse), make sure they are aware of the location of the Sun Lift when boat is not present, and lift is hidden under water.
12. Do not power boat on lift. Lower lift so boat glides into position. Boat must be in neutral to minimize risk to propeller. Lift is not designed to react loads from boat engine(s).
13. Lift structure, welds, bolts, pins and hydraulics must be inspected annually.  
The *Catwalk* accessory is not designed to hold people. Do not stand or walk on the catwalk.

**Safety tip:** Use your remote control to raise bunks out of the water after departing, therefore allowing swimmers to see location of lift.



## **USE AND MAINTENANCE**

Sunstream recommends an annual inspection of the Sunlift by a Sunstream dealer or other qualified personnel.

## **STORAGE AND OFF-SEASON SUGGESTIONS**

### **! WARNING**

Be sure to prevent rainwater from accumulating in your boat if you plan to leave it on the lift for long term storage. Rainwater accumulating in your bilge can quickly increase your gross weight over the lift capacity.

1. At all times, make sure that you adjust the height of the lift to limit wave action against the hull. Wave action will damage the lift and can take the boat off the lift.
2. We recommend disconnecting the **Powerpack** and storing it indoors for the winter if you are not planning on using the lift for prolonged periods. To do this, simply disconnect the hoses from your Powerpack by using the **Quick-Connects** and connect the hoses together. This will ensure that it will remain clean.  
  
*Tip:* If you have problems disconnecting the hoses from the Powerpack, operate the pump up and down while attempting to disconnect the hose to relieve the pressure. Do not disconnect the hoses when lift is pressured against the upper or lower stops.
3. Booster-charge your battery using a 10A charger at the beginning and end of the season. A mid-season boost may be required for heavy use.
4. If your waterway freezes during the winter, you will need to remove your Sun Lift, as it will be damaged by ice flow.
5. When storing the boat, the lift must be in the upright over center gravity lock position for maximum safety. The over-center position will prevent the boat from lowering if you experience a hydraulics leak.
6. Your Sun Lift can be left in any position when not in use. Although we do recommend leaving the lift in the up position to prevent the bunks from becoming 'slimy', and to avoid creating a hidden underwater obstruction.
7. It's suggested before storing your lift for the season, ensure boots are drained of all water.



# **BATTERY TIPS**

**Recommended Battery.** Use a 12V group 27 marine deep-cycle battery with a minimum of 500 CCA (or with a reserve capacity of 160 Amp Hours). Reserve capacity is the most important feature.

**Battery Capacity:** The SL4010 was tested to have a energy capacity of approximately 20 full cycles at using a new battery with a reserve capacity of 160 Ah. However, try to not dip below 50% battery capacity, since the solar panel would have difficulty in recovering from such a deep draw.

**Solar Charging rate:** The following values are limits on full cycles (down and up) to keep battery capacity at steady state condition. The capacity of the battery will allow for additional cycles for any particular month. Table assumes all-day exposure with typical seasonal weather.

Max. Monthly Full Lifting Cycles (Down and Up) using a single solar panel (keeping steady state energy level)		
Month	Seattle (a northern cloudy city)	San Diego (A sunny southern city)
Jan	2 cycles	27 cycles
Feb	8	29
Mar	14	29
Apr	18	31
May	21	27
Jun	22	25
Jul	24	28
Aug	24	31
Sep	19	29
Oct	12	29
Nov	4	28
Dec	1	25

If your solar panel does not keep the battery charged try any of these options:

- Move your solar panel to an area with less obstructed sunlight.
- Add a second solar panel, or add an a/c charger.
- Booster charge your battery mid-season.
- Check cell water levels in battery. Top up if necessary with distilled water.

# **REMOTE CONTROL PROGRAMMING INSTRUCTIONS**

Sometimes it may become necessary to re-program your remote transmitter. It is possible for the transmitter to de-program either due to loss of power (dead battery), or electrical interference.

If your remote will not work, first check to see that it is transmitting. Do this by depressing any of the three buttons and watching to see that the red LED light is working. If so, then the next step is to re-program the receiver.

### **RC306 Programming Instructions**

1. SWITCH RC UNIT TO \*OFF\*.
2. SWITCH RC UNIT TO \*ON\*.
3. STEADILY PUSH & RELEASE **PROGRAM SWITCH** 3 TIMES.
4. STEADILY PUSH TRANSMITTER \*UP\* BUTTON 3 TIMES, ON FOURTH PUSH, POWER UNIT SHOULD RUN.



## **TROUBLE-SHOOTING TIPS**

**Cannot connect hoses.** USE EYE PROTECTION FOR THE FOLLOWING PROCEDURE!

The hoses may be difficult to connect if the system is pressurized. To de-pressurize the hoses, push in the button on the end of the nipple on the male fitting. If needed, the female quick disconnect fitting on the hose can be depressurized by carefully pressing the internal button using a 3/8" bolt. Be careful not to upset the internal O-rings. It is best to wrap the fitting with a rag while depressurizing to prevent spray. Be careful to keep the connectors clean.

The pump can be de-pressurized by tapping the 'up' switch briefly to de-pressure the female fitting. The Male fitting can be depressurized by carefully pressing the button on the end of the nipple or by briefly tapping the down switch. Use caution to avoid damaging the nipple button. To prevent pressure in the hoses in the future, do not disconnect the hoses if the lift is pushing against the upper or lower stops.

**Lift stops after a split second.** This is a sign of a low battery. If your battery is becoming low, the remote control will stop functioning (at about 11 volts). The lift can still be operated using the up/down switch in the powerpack. The pump motor will stop functioning if the voltage drops below 9 volts. Charge the battery using a 10A charger.

**Battery does not keep a charge.** Check the battery fluid levels, age and time of last booster charge. (The Battery needs to be booster charged in the beginning and end of the season using a 10A charger.) Verify solar panel or a/c charger is plugged in correctly. Check the voltage output of the solar panel. Output should be about 14-18 volts when exposed to light. Verify the polarity (i.e. positive/negative) of the solar panel matches the battery's polarity. Verify your solar panel gets an appropriate amount of light and the lift usage is within the monthly seasonal limits. Your solar panel may be mounted up to 50 ft away from the battery if necessary. You may also order a bracket to mount your solar panel on top of your canopy. The remote control should only be drawing about 5 mA, and the pump 20mA (at rest). The solar panel has an output of approximately 750mA in direct sunshine.

**Battery terminal becomes hot.** Verify cable is clean and tight on battery terminal.

**Limited range of remote control.** Check battery in key-chain transmitter. If your range is only limited while in your boat, try holding the transmitter over your head. Proximity to cell phone towers, power lines and other electromagnetic interference can also reduce remote control range.

**Remote control not functioning.** The remote control is designed stop working if the battery drops below 11 volts to alert the user that the battery is getting low. If the lift operates with the up/down switch in the powerpack but not the remote, charge the battery using a 10A booster charger.

NOTE: Remote "times out" after 30 seconds to prevent battery discharge in case button is accidentally held down (in a pocket, for example).

**Fluid overflows reservoir.** It is OK to see some fluid overflow from the reservoir when cycled all the way down for the first time only. Wipe up overflow with a rag or sponge.

**Lift does not go down.** Verify all wires are connected to switching solenoids (2 on the manifold block and one on the motor).



## Standard Warranty

**WARRANTY:** Sunstream Corporation (“Company”) warrants its Products for non-commercial and/or non-governmental use for a period of three (3)\* years, in both fresh and salt water, to the original Purchaser (“Purchaser”) against manufacturing defects in all Product materials and workmanship beginning from date of purchase of the Product from Company\*\* under the following terms and conditions:

**NOTICE REQUIREMENTS AND REMEDIES:** If the Purchaser discovers a defect, the Company, or its authorized Company dealer or agent, will, at the Company’s option: (1) repair the Product, (2) replace the defective part, or (3) refund the purchase price of the Product upon confirmation by Company that the Product is defective, provided that the Company receives notice of the defect from the Purchaser or Company dealer before the warranty period lapses. Product changes caused by age or environment (such as marine growth or heat) shall not constitute a defect. Confirmation of the defect shall require that reasonable proof of the defect be provided by Purchaser to Company or Company dealer, and may include that the Product or part be returned to Company for inspection at Purchaser’s initial expense. This warranty shall not apply if Company receives notification after the before-stated deadline, regardless of when the defect occurred or was discovered, and regardless of the reason for the delay in notification. “Notification” shall be deemed to have occurred when the Purchaser or Company dealer sends written notice to Company by fax or by e-mail and when receipt is confirmed by Company’s response.

**EXCLUSIONS:** This warranty does not apply to damages caused by or due to: (1) accident (including, without limitation, collision, fire, flood, wind, ice or any other natural disaster or acts of God), abuse, misuse, overloading, out of level or improper boat loading (i.e.: not fully on, too far on, or crooked on lift), or (2) faulty assembly or installation if such assembly or installation was not performed by a Company employee or Company dealer. Company is not responsible for determining the weight or dimensions of Purchaser’s boat, and Purchaser is advised that published boat specifications are often inaccurate. This warranty is void if the Product has been modified without the permission of the Company or if any Company serial number has been removed or defaced. Normal maintenance requires an annual inspection of the Product by a Company employee or Company dealer, including bolts, pins, hydraulics, pump, electronics, and welds and failure to undertake such maintenance may constitute “abuse.” Lift components’ fluid level and condition, including battery water and acid, SunFluid and strainer cleaning are maintenance items and are not covered by this warranty. Zincs, ropes, batteries, cosmetic concerns and custom coatings are not covered by this warranty. Batteries supplied by Company that are maintained in top operating condition by Purchaser are warranted for a period of one (1) year. Underwater light systems and the DockJock are not warranted for use in brackish or salt water. This warranty does not void or alter any rights the Purchaser may have against dealers or suppliers of component parts.

**SALT WATER REQUIREMENTS AND EXCLUSIONS:** If any Company Product is used in brackish or salt water, the Purchaser agrees that proper maintenance requires that the Purchaser shall attach to the product, maintain and regularly check sacrificial anodes, also known as “zincs,” in order to prevent electrolysis from damaging the lift metals, and that failure to attach and maintain the zincs constitutes “abuse.” \*\*\* Underwater light systems and the Dock Jock™ personal watercraft lifts are not warranted for brackish or salt water use regardless of zinc use.\*

**INTERNATIONAL WARRANTY:** The Purchaser agrees that if the Product leaves the borders of the United States of America, Puerto Rico or Canada, replacement parts shall be shipped with the dealer’s next container order. International dealers have the option of using parts from stocked product if possible to expedite response. Purchaser has the option to pay for expedited freight if desired.

**LIMITATIONS:** Except as expressly stated herein, there are no warranties, expressed or implied, by operation of law or otherwise, of the Product furnished under this Agreement. Seller disclaims any implied warranty of merchantability or fitness for a particular purpose. The sole remedy for liability of any kind shall be limited to the remedies provided in this warranty and shall in no event include any incidental, indirect, special or consequential damages or loss of use, revenue or profit. State law may override the above exceptions or limitations.

\*Fresh water applications for underwater light systems and the Dock Jock™ winch and strap are warranted for one (1) year; salt water applications are not warranted for these Products.

\*\*If the Product is purchased from a Company dealer, the warranty term begins upon the date the Product is sold to the end Purchaser or three (3) months from the date the Product is shipped from Company, whichever occurs first.

\*\*\*Under normal conditions, zincs should last at least one (1) year. If Purchaser observes that the zincs are deteriorating in a shorter time period, an external current could be entering the system and the Purchaser must find the source of this current and stop it, or change zincs more frequently.

---

### Sunstream Corporation

22149 68<sup>th</sup> Avenue South

Kent, WA 98032

USA

Web Site: [www.sunstreamcorp.com](http://www.sunstreamcorp.com)

Phone: 001-253-395-0500

E-mail: [mailbox@sunstreamcorp.com](mailto:mailbox@sunstreamcorp.com)

Fax: 001-253-395-0501